



Floodline

Leak and Flood Detection Systems

DD-nn Digital Gas Sensor

Installation and Operation Manual



Andel Limited
Unit 1 Dodworth Business Park South,
Upper Cliffe Road,
Dodworth,
Barnsley
S75 3SP

Tel +44 (0) 1484 845000
Fax +44 (0) 1484 845222

www.andel.co.uk

Contents

Introduction.....	3
Installation.....	4
Mounting.....	4
Supply Connection.....	4
Relay Connections.....	5
Floodline Multi Zone Panel Connection.....	5
Operation.....	5
Power Up.....	5
Leak Detected.....	5
Technical Specifications.....	6

Thank you for selecting the Floodline (FLD) DD-nn digital gas detector. This manual provides installation and operation information. Please read before installing or operating and retain for future reference.

Introduction

The Floodline DD-nn digital gas detector is designed to continuously monitor for the presence of the specified gas. They are designed to be installed in hotels, offices, public buildings etc. When the set concentration values are exceeded, the detector generates a visual / audible alarm and changes the state of the output relay within the DD-nn detector.

The unit also has RS-485 network capabilities for connection to the Floodline MDD-256/T gas detection system which gives more detailed alarm information. Each sensor has 3 alarm levels A1, A2 and A3 set at different levels depending on the type of gas being detected.

The detector has a removable module with an intelligent semiconductor sensor, which facilitates maintenance and lowers operating cost.

The sensor is available to detect 5 gas types which are defined by the 'nn' number of the device, the table below gives details for these codes and the A1 to A3 alarm levels. The code number is clearly marked on the removable detection module.

Code Number	Detectable Gases
DD-11	Natural Gas/CNG, other hydrocarbon A1= 10%, A2 = 20%, A3 = 30%
DD-14	Natural Gas/CNG (selective to CH4) A1= 10%, A2 = 20%, A3 = 30%
DD-15	Propane/butane/LPG, other hydrocarbons A1= 10%, A2 = 20%, A3 = 30%
DD-22	Carbon monoxide (CO) A1= 20ppm, A2 = 100ppm, A3 ≥ 250ppm
DD-61	Chlorofluorocarbon (HFCs) A1= 1000ppm, A2 = 2000ppm, A3 = 2500ppm

The main features of the detectors are:

- Long life, semiconductor gas sensor
- Ease of installation and connection (detachable terminals)
- RS-485 port (isolated) with Modbus RTU protocol (for connection to MDD-256)
- 3 Standard alarm thresholds (A1, A2, A3 factory set)
- Relay output (set for A2 threshold as standard) NO/NC type (switch up to 30Vdc)

- Audible alarm (can be disabled with built in jumper)
- Sensor is removable, intelligent module
- Built-in microprocessor control for reliability and stability
- Stylish housing, for wall mounting cable back entry or mounting to a typical 1-way pattress box or Ø60mm, flush-mounted box with screws at the edge

Installation

The detectors are designed to be wall mounted and 2 fixing holes are available in the back of the unit for mounting to the support surface. The position of the sensor will depend on the type of gas being detected and specific site conditions.

The diagram below shows the layout of the user terminal and their connection details:

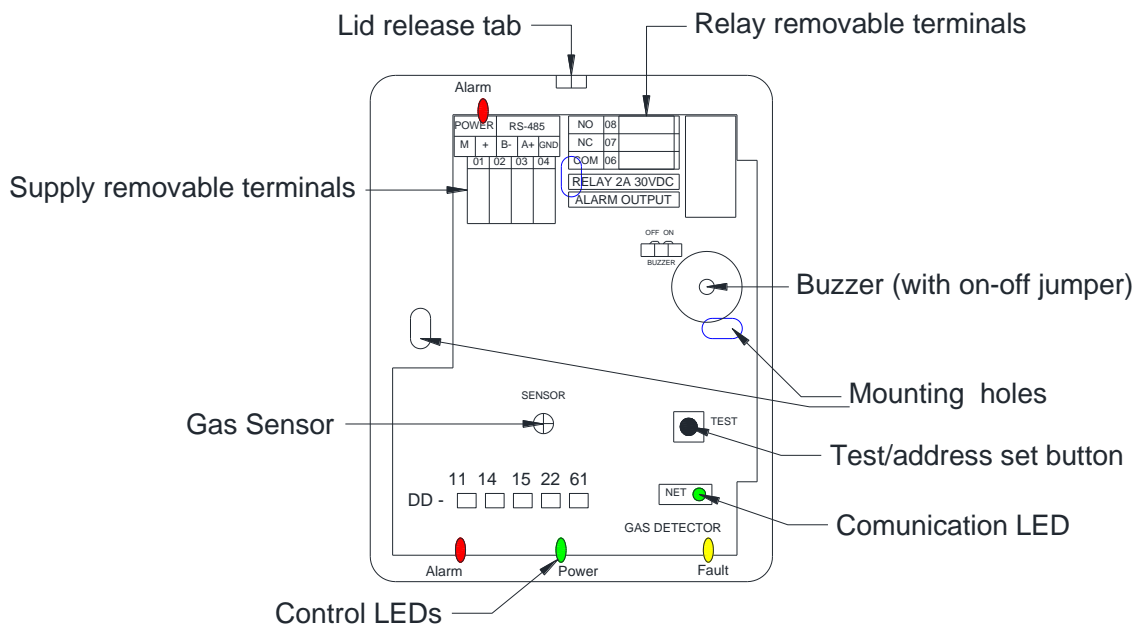

Mounting

To access the unit, press firmly the top of the enclosure lid until the lid release tab is released, or press the lid release tab with a screwdriver. The sensor module PCB can then be removed in order to access the enclosure mount holes. Once mounted the sensor module PCB should then be reinstalled.

Supply Connection

The supply connections are via the quick connect terminals, terminal 01 (m) is connected to 0V and terminal 02(+) is connected to 24Vdc.

Relay Connections

The alarm status of the detector can be monitor directly using the relay outputs which are clearly labelled;

- NO = Normally Open terminal 08
- NC = Normally Closed terminal 07
- COM = Common terminal 06

Floodline Multi Zone Panel Connection

If connecting to a Floodline Multi Zone Control Panel, then connections should include resistors to simulate the monitoring characteristics of the Floodline Multi Zone Panel. Figure below shows these connections and resistors needed:

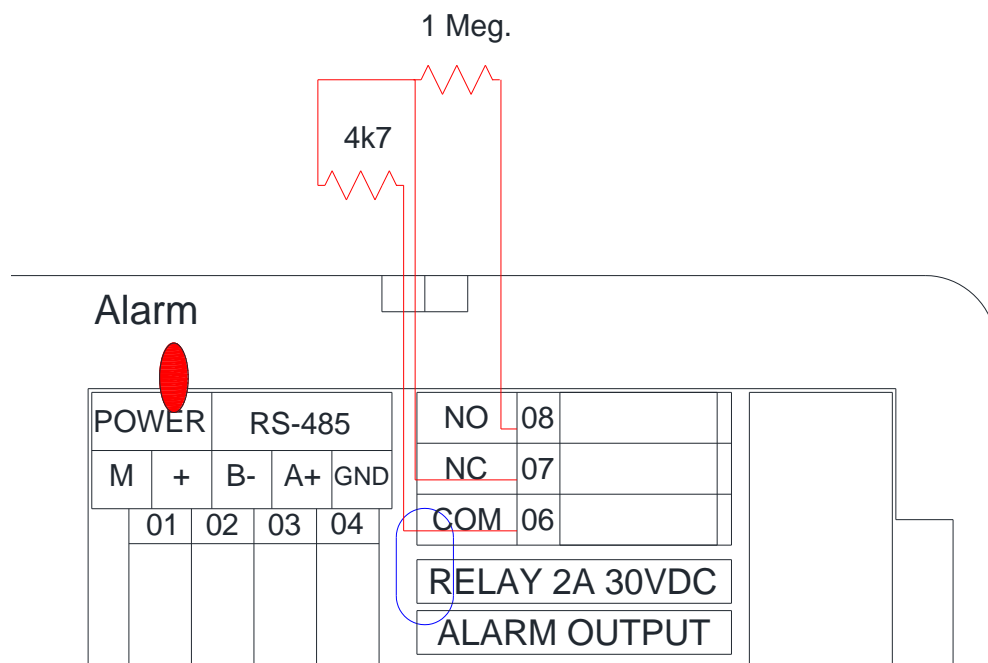

Operation

Power Up

On power up the unit's a self-test is performed. During the self-test, the audible alarm sounds, the alarm, fault, Net and power indicators flash. Once the self-test is completed, the sounder turns off and the power indicator flashes. The unit is now in sensor setting period (approximately 1 minute). Once this settling period has elapsed the power LED with stay lit, the detector is now in the standard monitoring mode.

Leak Detected

When the gas in the area being monitored goes above the threshold levels the system will generate and alarm the table below gives detail of the alarm types:

Status	Alarm LED	Power LED	Fault LED	Relay	Buzzer
Normal	off	on	off	off	off
A1	flashing 1s	flashing	off	off	on
A2	flashing 0.5	flashing	off	on	on
A3	on	on	off	on	on
Fault	off	flash	flash	off	on

Once the gas concentration falls below the leak threshold the detector will automatically reset.

Technical Specifications

Power supply	24V DC (range: 10 ÷ 30V)
Supply current	max 30mA @24V DC
Operating temperature range	from -5°C up to +45°C recommended, -15°C to +50°C allowed periodically (<1h/24h)
Relative air humidity range	from 30% to 90% RH
Gas sensor	semiconductor type, in a removable module; estimated life time in the clean air - about 10 years
Detectable gases	DD-11: Natural gas/CNG, other hydrocarbons DD-14: Natural gas /CNG (methane selective); DD-15: propane-butane/LPG, other hydrocarbons DD-22: carbon monoxide, range 20 ÷ 1000 ppm DD-61: HFC (Freon) type R134A, R407C or R410A
Interfering factors	hydrogen, alcohol (high concentrations), chloride, a significant oxygen deficiency (<19% vol.), a large, rapid increase in humidity, long-term presence of gases with concentrations > 1% LEL (combustible gases) or > STEL (toxic gases)
Alarm thresholds (standard)	ALARM = 2000ppm Freon R410A (DD-61) or 100ppm CO (DD-22); or 15 % LEL (combustible gases -DD-11,14,15)
Alarm threshold accuracy	± 15% rel. for the recommended calibration conditions
Threshold thermal stability	± 15% in range 0°C to 40°C
Long term stability	± 20% rel./year, not more than ± 30% in 3 years
Calibration interval	recommended: < 36 months
Communication port	RS-485 isolated, MODBUS RTU protocol; plug in connectors
Signaling: optical	lamps: LED – ALARM = red; POWER = green Fault Yellow
acoustic:	65dB/30cm, piezoceramic buzzer (switchable by jumper)
Relay output	NO/NC type; max 2A/30VDC; plug in connectors
Dimensions	100 x 80 x 30 mm, H x W x D
Housing, weight	ABS, IP30; approx. 90 g